

IMPORTANT:

If your car was equipped with charcoal canister (EVAP) valve operated by ECU (connected to ECU pin 7), DISCONNECT the valve from ECU pin 7, otherwise either ECU or valve damage will occur.

1 pulse per rev. If you have problems getting the correct readings, see RP Lab FAQ.

50% duty cycle 0-5v signal. Each half revolution it has a transition (from 0 to 5v, or from 5v to 0v). Total period is one rev. Load connected should have minimum input impedance of 10kohm.

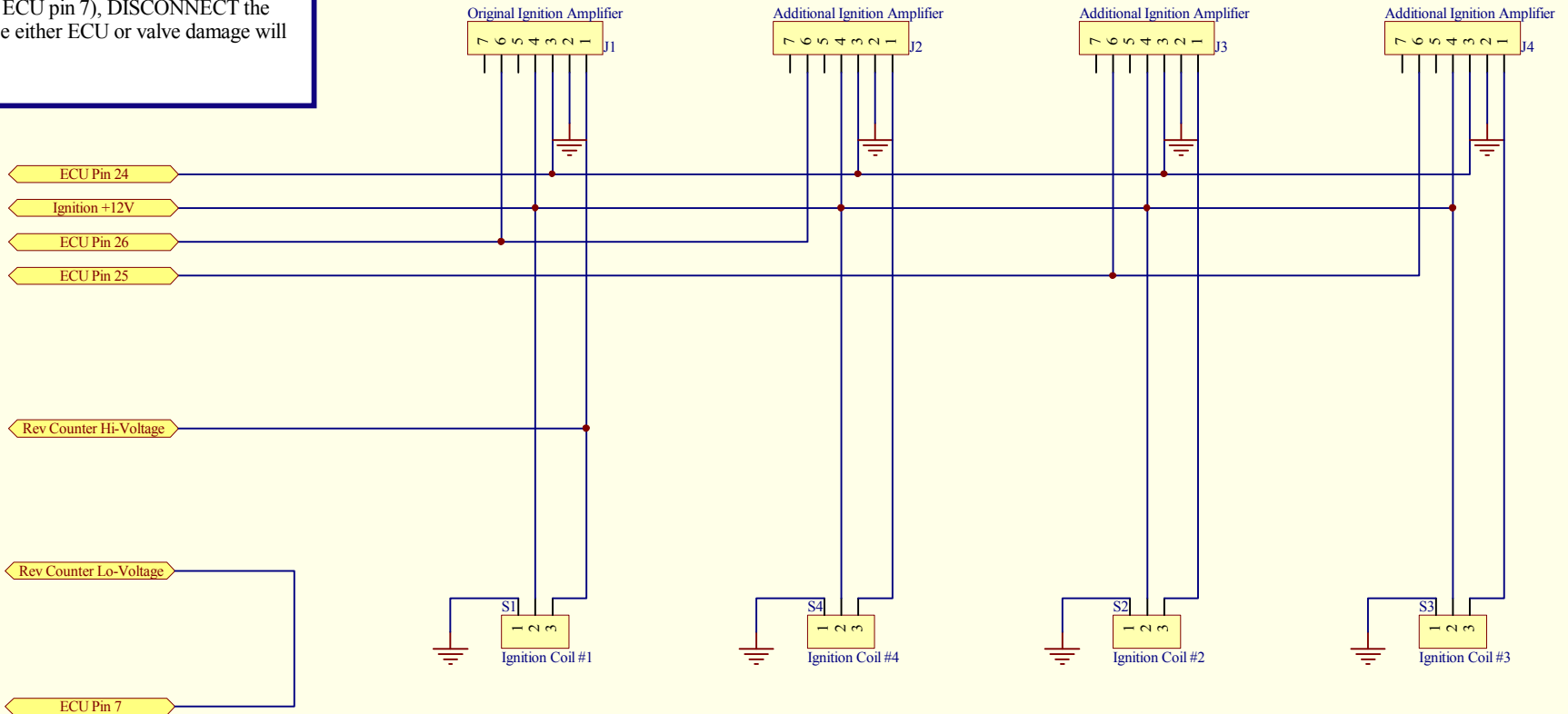
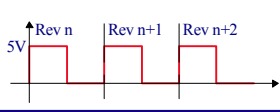

RP Lab
IAW Weber Marelli Specialists
<http://rptune.eu.org>

COIL-OVER-PLUG IGNITION - WASTED SPARK CONFIGURATION L8 ECU

Size A4	FCSM No.	DWG No.	Rev
Scale	Sheet 1 of 1		